

## GAD-502-P Levelling Glide

### Features

- Cross-recessed bottom allows easy installation with electric screwdriver
- Cover installed at the bottom to prevent scratching of floor available

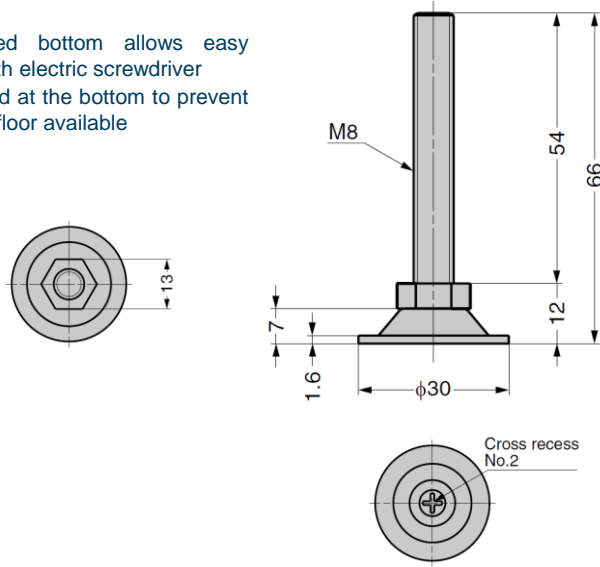

Base

Part No.	Material	Finish	Load Capacity (per piece)	
GAD-502P	Steel	Coloured Zinc Chromate (Trivalent)	2,744 N	280 kg
GAD-502P-BZC		Black Chromate (Trivalent)		

## GAD-502 Levelling Glide

### Features

- Cover installed at the bottom to prevent scratching of floor available

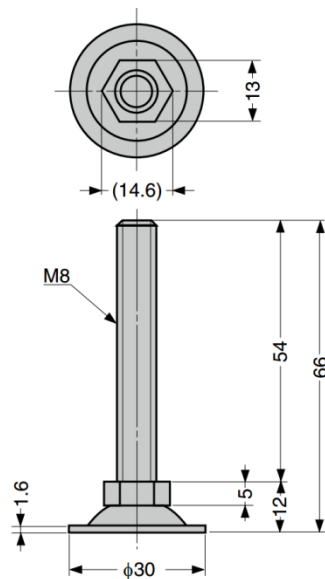

Part No.	Material	Finish	Load Capacity (per piece)	
GAD-502	Steel	Coloured Zinc Chromate (Trivalent)	2,744 N	280 kg
GAD-502BZC		Black Chromate (Trivalent)		